

SENECA XVAULT STORAGE QUICK START GUIDE

XVAULT ST3000

THIS PRODUCT MUST BE REGISTERED!

Email Seneca the serial number and software serial number located on top left front corner of enclosure along with “Hardware Challenge” to **storage_license@senecadata.com**. Reference manual, under “Licensing”, for instructions on how to retrieve “Hardware Challenge”. License files will be emailed back to enable full functionality. This unit has a temporary 30 day storage, snapshot, and replication license.

CONTENTS OF XVAULT PACKAGE

Quantity	Item
1	xVault xVOS Storage Appliance - Rackmount Enclosure
1	Set of Slide Rails Including Mounting Hardware
2	AC Power Cords
1	4 GB USB Flash Thumb Drive for Emergency Restore
1	USB to Serial Adapter
1	Null Modem Cable

CRITICAL INFORMATION:

DEFAULT LOG IN INFORMATION

Username: administrator

Password: P@ssw0rd

Note: This user has administrative privileges.

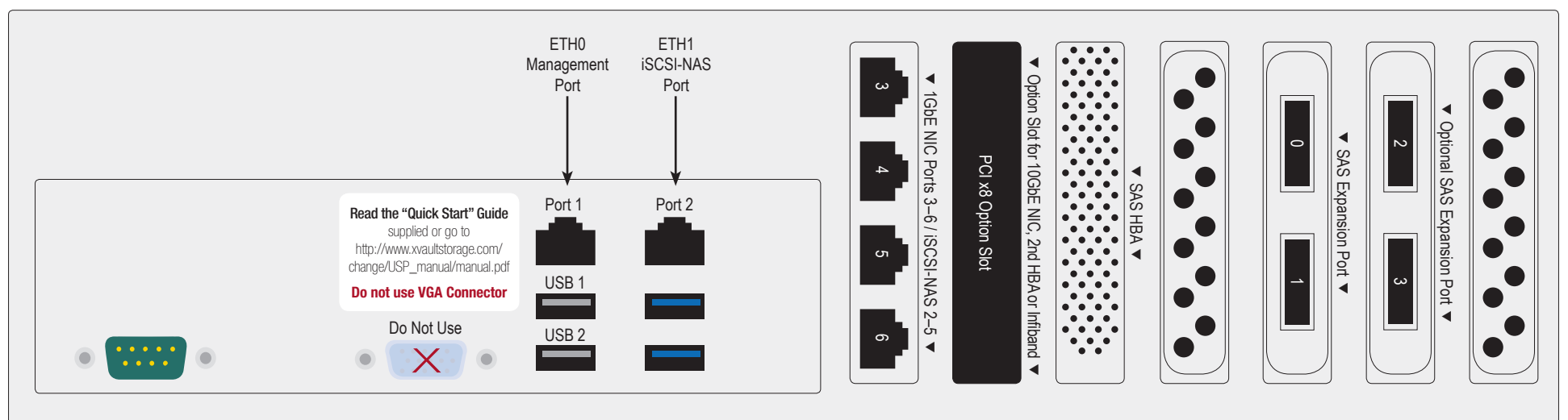

MAIN BACK PANEL CONNECTIONS

I/O Port Connection	Port Usage
NIC Port 1	Management Port
NIC Port 2-6	iSCSI / NAS 1
NIC Port 7-8	Optional 10GbE Ports
VGA	DO NOT USE
USB Port 1	
USB Port 2	
USB Port 3	
USB Port 4	
SAS Expansion Port	See manual for SAS port use

DEFAULT 1GBE FIXED IP ADDRESSES

Port	IP Address	Mask
Management Port	172.16.6.14	255.255.255.0
1GbE Port 1	10.0.10.31	255.255.255.0
1GbE Port 2	10.0.10.32	255.255.255.0
1GbE Port 3	10.0.10.33	255.255.255.0
1GbE Port 4	10.0.10.34	255.255.255.0
1GbE Port 5	10.0.10.35	255.255.255.0
1GbE Port 6	10.10.10.3	255.255.255.0
10GbE Port 1	10.10.10.4	255.255.255.0
10GbE Port 2		

DRIVE SLOT LOCATIONS BY CHASSIS MODEL

xNVR 3U 16 BAY



xNVR 4U 24 BAY



WARNING: Power on self test takes several minutes until boots process.

INITIAL SETUP OUTLINES:

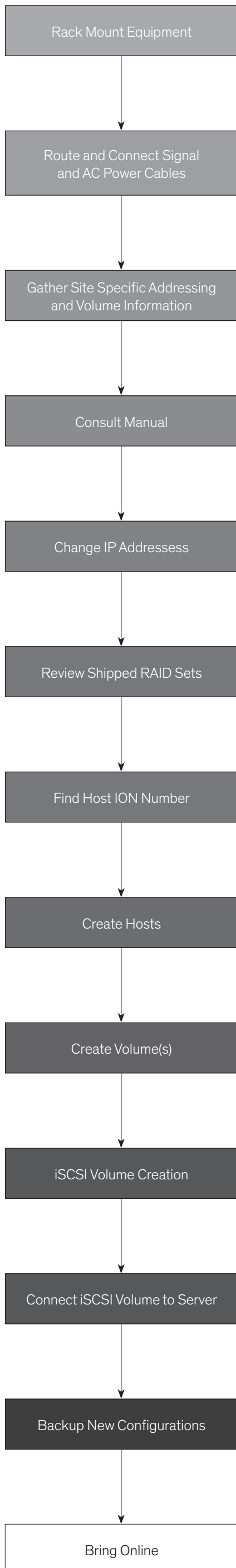

HOW TO CONFIGURE ALERTS

1. Select **Administration**, then **Setup** then **SMTP Setup**

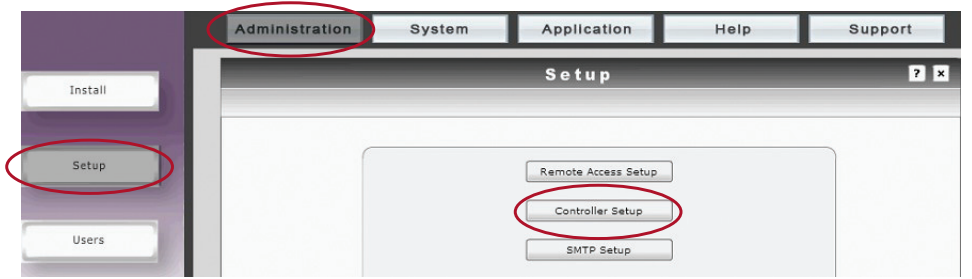

2. Enter mail server URL or IP Address in Host field. Port is usually 25, check with your email administrator to verify. If the SMTP server requires authentication check **Yes** and enter user and password information.

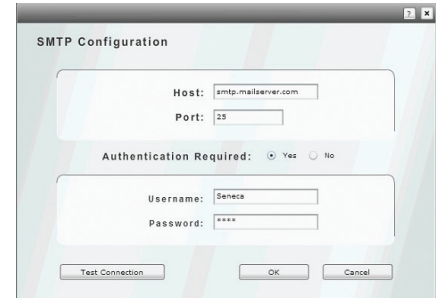

3. Set alert notification recipient by selecting Help, Alert Management and clicking on Add.

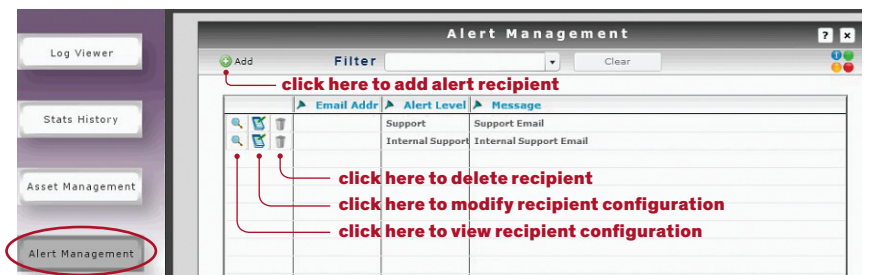

4. Enter Email Address, set Alert Level that user will receive. Enter the base Message, this message becomes the subject line of the email and should identify the xVOS storage appliance sending the alert. Consult the manual for more information.

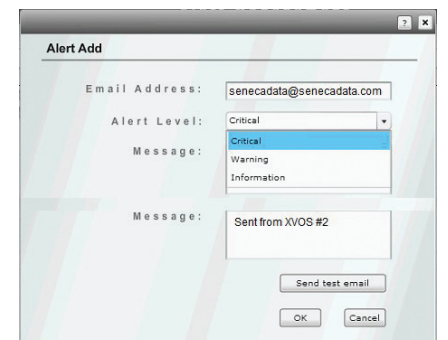

NOTE: Please reference manual for more detailed configuration information.

Manual Location:

The online manual link in PDF format can be opened by navigating from the log in screen by selecting **Support** then selecting **Support Portal**.

The manual can also be downloaded at <http://products.senecadata.com/PDF/support/storage/ST3000-manual-V2.PDF>.

XVAULT SUPPORT

Seneca customer care group stand ready to assist with any hardware and operating system assistance.

Contact Seneca Digital Security and Surveillance Support:

Normal Business Hours
800.227.3432 option 5
Available Monday–Friday 8am–6pm EST

Outside Business Hours
888.227.9994

First level of data protection and integrity begins with AC power protection.

Please consult your Seneca Account Manager for properly sized, uninterruptable power supply (UPS).